

World Best Quality

ICETRO 霜淇淋機

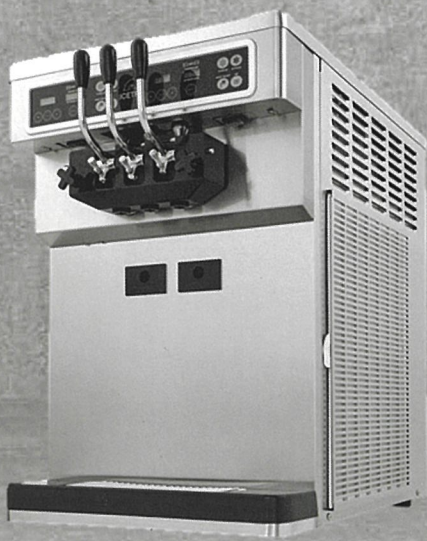

ISI-163TT

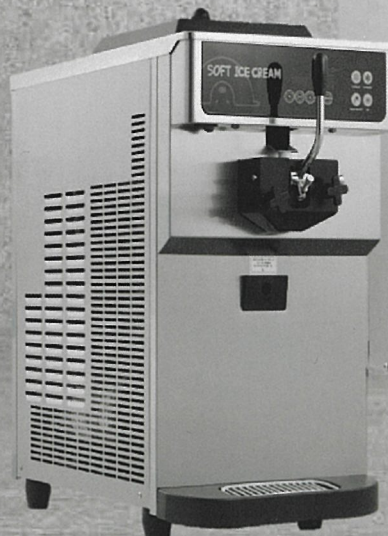

SSI-151TG



ISI-161TH

世界品質第一的迷你霜淇淋機

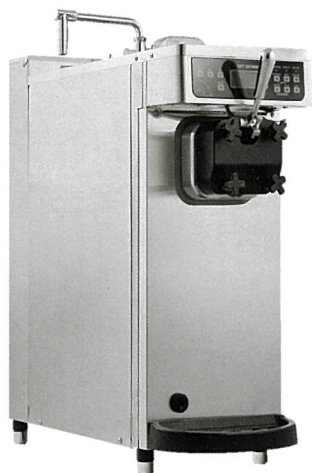

ISI-161TH



LCD 顯示螢幕



均溫攪拌器



頂端排氣

外觀規格

ISI-161TH	
淨尺寸	
寬度	300 mm
深度	775 mm
高度	750 mm
重量	89 kg

電壓規格

ISI-161TH	208~230V / 60Hz / 1Ph
-----------	-----------------------



冷凍缸
· 1.6 L x 1



直驅馬達
低噪音與低震動



熱處理系統 (巴氏殺菌系統)
對奶漿進行一段時間的加熱進行殺菌，讓設備可維持 14 天再做清洗



儲料槽
· 3 L x 1
· 在 Auto & Standby 模式保持在 5°C 以下



均溫攪拌器
將儲料槽維持在穩定的溫度，避免奶漿產生分離的狀況

全新桌上型霜淇淋機



ISI-163TT



SSI-151TG

外觀規格

	ISI-163TT	SSI-151TG
淨尺寸		
寬度	510 mm	404 mm
深度	745 mm	730 mm
高度	800 mm	695 mm
重量	179 kg	95 kg

電壓規格

ISI-163TT	208~230V / 60Hz / 1Ph
SSI-151TG	208~230V / 60Hz / 1Ph

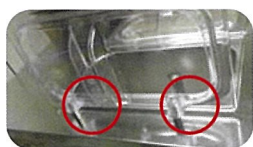

蓋塞



攪拌器



幫浦

* 163TT : 重力式



奢華簡約設計
觸控螢幕按鈕及簡約介面設計能夠搭配任何空間



簡易操作
直觀設計能輕鬆上手快速出杯

選擇適合您的霜淇淋機

單口味



ISI-151TG

儲料槽容量	10.0 公升
冷凍缸容量	1.4 公升
能源消耗	1.37 kW
最大產能	16 Kg (每小時)
首次出杯所需時間	6-9 min
可連續出杯量	5-6 杯 (100cc / 杯)

雙口味



ISI-163TT(P)

儲料槽容量	5.5 (12.5) 公升 x 2
冷凍缸容量	1.6 公升 x 2
能源消耗	2.70 kW
最大產能	24 Kg (每小時)
首次出杯所需時間	6-8 min
可連續出杯量	7-10 杯 (100cc / 杯)

Heat Treatment

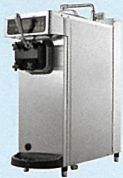

ISI-161T/TH

儲料槽容量	3.0 公升
冷凍缸容量	1.6 公升
能源消耗	1.30 / 1.40 kW
最大產能	12 Kg (每小時)
首次出杯所需時間	6-9 min
可連續出杯量	5 杯 (100cc / 杯)

Heat Treatment



ISI-163TTH

儲料槽容量	9.5 公升 x 2
冷凍缸容量	1.6 公升 x 2
能源消耗	2.85 kW
最大產能	24 Kg (每小時)
首次出杯所需時間	6-8 min
可連續出杯量	7-10 杯 (100cc / 杯)

Heat Treatment



ISI-271THN(P)

儲料槽容量	9.5 公升
冷凍缸容量	2.7 公升
能源消耗	2.17 kW
最大產能	21 Kg (每小時)
首次出杯所需時間	7-11 min
可連續出杯量	8-10 杯 (100cc / 杯)

Heat Treatment



ISI-273SHLN(P)

儲料槽容量	9.5 公升 x 2
冷凍缸容量	2.7 公升 x 2
能源消耗	4.20 kW
最大產能	42 Kg (每小時)
首次出杯所需時間	7-11 min
可連續出杯量	16-40 杯 (100cc / 杯)

Heat Treatment



ISI-301TH(P)

儲料槽容量	17.5 公升
冷凍缸容量	3.2 公升
能源消耗	2.0 kW (2.2 kW)
最大產能	30 Kg (每小時)
首次出杯所需時間	8-10 min
可連續出杯量	15-18 杯 (100cc / 杯)



型號中 (H) 代表含熱處理功能
定時殺菌，可14天清洗



(P) 代表含泵浦
提高攪拌效率，使霜淇淋質地更加柔軟順口

* 產品外觀與規格如有變更，恕不另行通知。



簡單操作 — 輕鬆上手的霜淇淋機

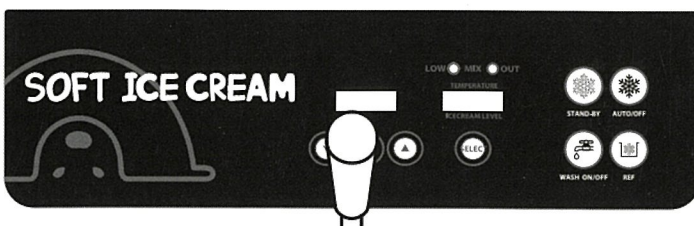

ICETRO 霜淇淋機透過「簡易的觸控操作」與「清晰的顯示燈號」，讓您快速了解霜淇淋機狀態，馬上開啟您的霜淇淋生意





hos.dksh.tw

韓國第一領導品牌

Pride of No.1 brand in Korea

我們致力於提供頂級的設備產品及優質的客戶服務

ICETRO 象徵著卓越品質及最高價值，我們的核心是持續努力以成為全球矚目的品牌企業。



簡約



可靠



高性能



台灣大昌華嘉

亞洲深耕150年，台灣經驗60年，足跡遍布世界36國

台灣大昌華嘉餐飲設備事業部已在台灣深耕60年，提供台灣餐飲業最新、最完整的餐飲設備服務。我們與歐美知名品牌合作，提供最適合餐飲業的頂級設備，並擁有最完善的全台售後服務網絡。



台灣總代理 台灣大昌華嘉 <https://hos.dksh.tw/>

北部：114 台北市內湖區堤頂大道二段407巷22號10樓 / 電話：02-8752-6326

中部：408 台中市南屯區益豐路四段436, 438號 / 電話：04-2385-2668

南部：806 高雄市前鎮區新衙路286-2號2樓之1 / 電話：07-815-0951



ICETRO 產品頁



ISI-161TH

W x D x H inch (mm)
 12" (300) x 34" (854) x 34" (871)



Feature



SIMPLICITY



PERFORMANCE



RELIABILITY



EXCELLENT TASTE



Direct Motor Drive (operation)

Less noise & Less vibration



Heat Treatment System (Pasteurization)

Pasteurization involves heating dairy products for a period of time to kill bacteria, maintaining dairy products up to two weeks. You can also choose an automatic or manual pasteurization system.



Agitator operation

Keep ice cream mix liquid separation / Circulate the ice cream mix evenly for temperature maintenance



Mix Hopper

One, 3 liter (0.8 gallon) / Maintain the temperature of mix, under 5°C (41°F) in Auto & Standby modes



Freezing Cylinder

One, 1.4 liter (0.4 gallon) x 1EA



Various Function

Defrost / Regeneration / Boiling Function



Artificial Intelligence Control System

A.I Control System makes high quality soft serve ice cream.



Slim & Compact Design (Excellent space utilization)

Mini sized machine secures room for limited space



Dimensions

Dimensions	Net	Gross
Width	12" (300 mm)	16" (400 mm)
Depth	34" (854 mm)	33" (850 mm)
Height	34" (871 mm)	33" (850 mm)
Weight	196 lbs (89 kg)	238 lbs (108 kg)

Certification



7, GEOMDAN-RO 54BEON-GIL, SEO-GU, INCHEON, KOREA

• TEL : +82-32-814-2160 Ext. 210, 220 • FAX : +82-32-814-1798

• WEB : www.icetro.com • E-mail : sales@icemaker.co.kr

PREMIUM HEAT TREATMENT MINI SOFT ICE CREAM MACHINE

Dimension – Unit : mm (inch)

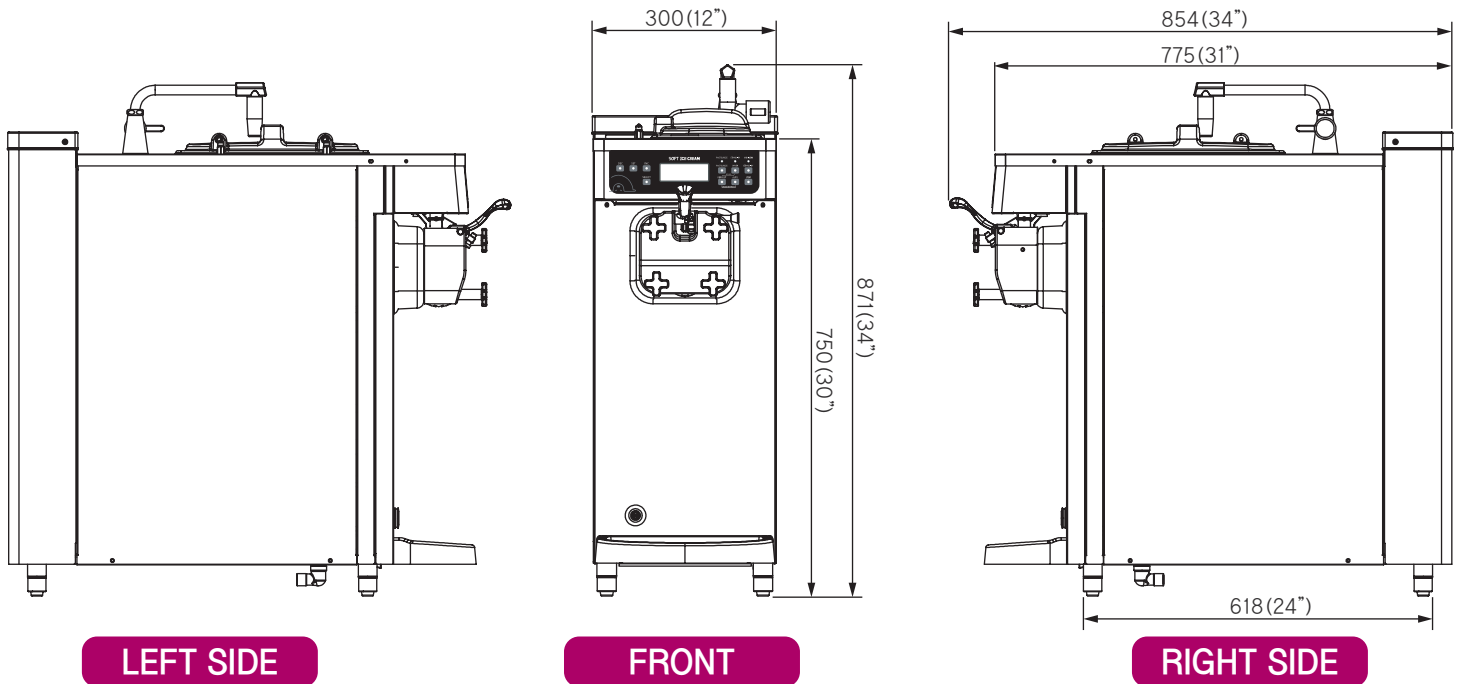

Specification

Model	Mix Hopper Capacity	Cylinder Capacity	Consecutive Dispensing	Dasher Motor	Max. Production
ISI-161TH	3 liter (0.8 gallon)	1.4 liter (0.4 gallon)	5 cups (100 cc/3.5 oz)	0.35 KW	12 kg (26.5 lbs/h)
	First Dispensing	Power Consumption	Compressor Capacity	Cooling System	Electrical Option
	6~9 min	1,400 W	1 HP (R-404A)	Air-Cooled	230V/50Hz/1PH 220V/60Hz/1PH

※ Production Capacity may vary depending on ambient temperature.

Detail View



Simple & Easy to access operating / control system on the front LCD touch panel



Pull out to remove the Air filter at the bottom of the front side



Agitator Operation
Automatically Detect MIX OUT & MIX LOW by the sensor

※ Design and Specification are subject to change without notice.